

SONATA

Turnkey 1030 nm Yb Femtosecond Laser



DESCRIPTION

SONATA is a SESAM-free, all-PM femtosecond fiber laser engineered for excellent timing stability, clean pulse performance, and robust long-term operation. Its monolithic, fully integrated architecture ensures turnkey, maintenance-free use with minimal warm-up time.

Featuring dual isolated outputs, SONATA provides a chirped picosecond fiber output for amplification and a free-space output delivering ~150 fs transform-limited pulses for nonlinear optics and timing-sensitive measurements. The SONATA series also offers customizable repetition rates, center wavelengths and synchronization options to meet application-specific requirements.

BENEFITS

- Turn-key and user-friendly operation
- Rapid start-up in approx. 30 seconds
- Excellent frequency and intensity stability
- Low timing jitter and relative intensity noise

APPLICATIONS

- Ultrafast pump-probe experiments
- Seeding high-power amplifiers
- ASOPS setups
- Nonlinear microscopy

SPECIFICATIONS

| Parameter | Specification | | Comment |
|------------------------------|----------------------------|----------------------------|--|
| | Fiber output | Free-space output | |
| Center wavelength | 1030 nm ± 2 nm | | Other center wavelengths available on request |
| Spectral bandwidth | > 14 nm | | |
| Repetition rate | 40 MHz or 54 MHz | | Other rep. rates available on request |
| Pulse duration | > 3.0 ps, Chirped | < 150 fs | Transform limited pulse at free-space output |
| Avg. output power | ~ 10 mW | > 100 mW | |
| Pulse energy | 0.25 nJ | 2.5 nJ | |
| Beam quality | n/a | M ² < 1.1 TEM00 | |
| PER | > 20 dB | | |
| Laser output | PM fiber | 0.8-mm diameter | Collimated Gaussian beam |
| 100-h power stability | < 0.1 % at 100 mW | | Standard deviation |
| Free-running Rep. rate drift | < 1 ppm | | At stable room temperature (+/-0.5 °C) |
| Laser TEC tuning range | > 8000 Hz | | It can be used for as rep. rate stabilizing actuator |
| Slow PZT tuning range | > 350 Hz | | |
| Fast PZT tuning range | > 20 Hz | | |
| Power supply | 24 VDC | | |
| Laser dimensions | 295 × 290 × 120 mm (W×L×H) | | All-in-one laser unit |



MEASUREMENT DATA

The following measurement data was obtained with a SONATA laser delivering 40 MHz at an average output power of 100 mW.

Spectrum

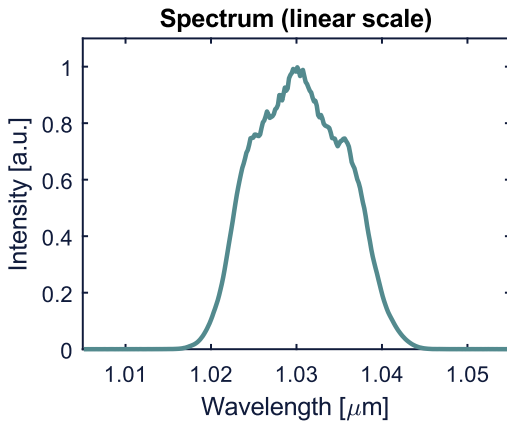

Autocorrelation

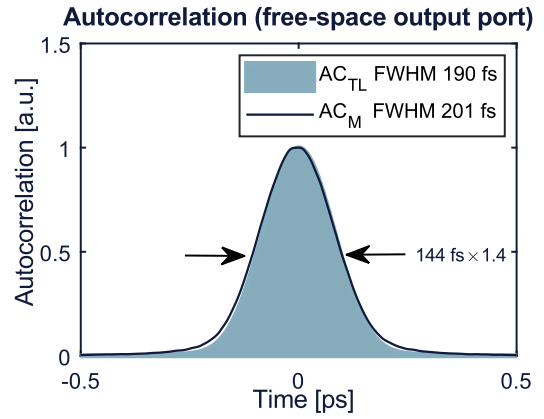

RF spectrum

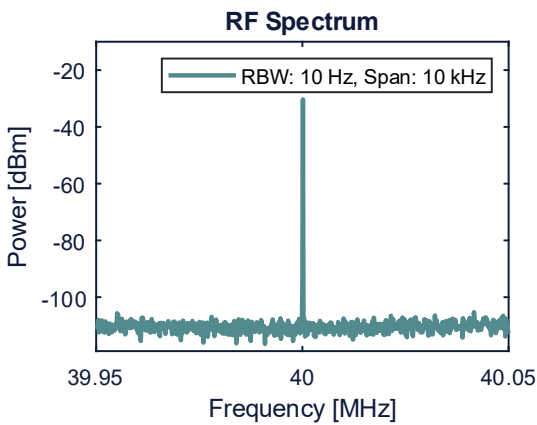

Power log

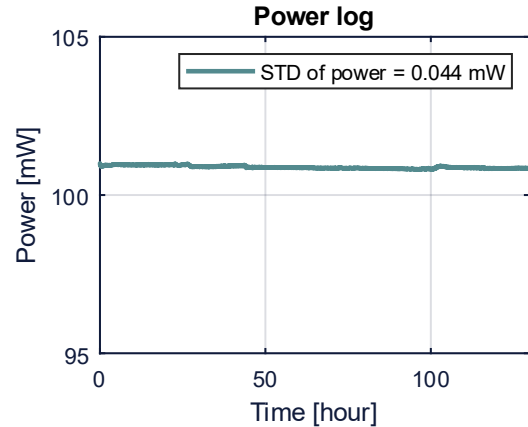

Timing jitter¹

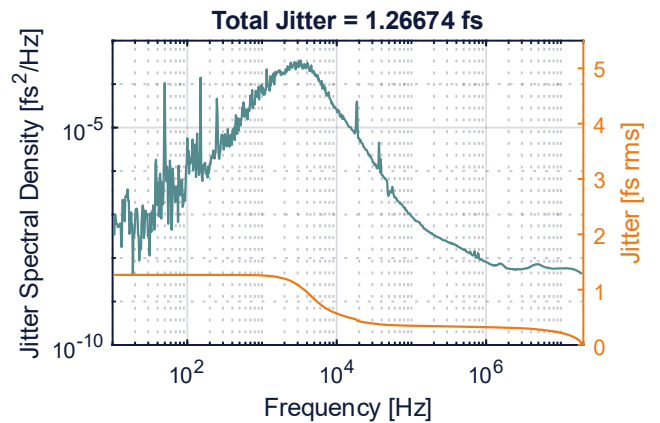
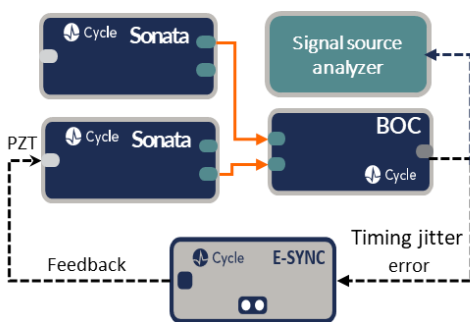

¹Two identical SONATA lasers are synchronized using the Cycle 1- μ m BOC timing-error detector and the Cycle E-Sync integrated PID/PZT controller. A feedback bandwidth of \sim 3 kHz enables out-of-loop timing-jitter measurement. Due to laser symmetry, the absolute timing jitter equals half of the relative jitter measured by the BOC and a signal source analyzer. The absolute timing jitter is 1.26 fs (3 kHz–20 MHz).